

*the functionally reduced option
 to the machine series C1S*

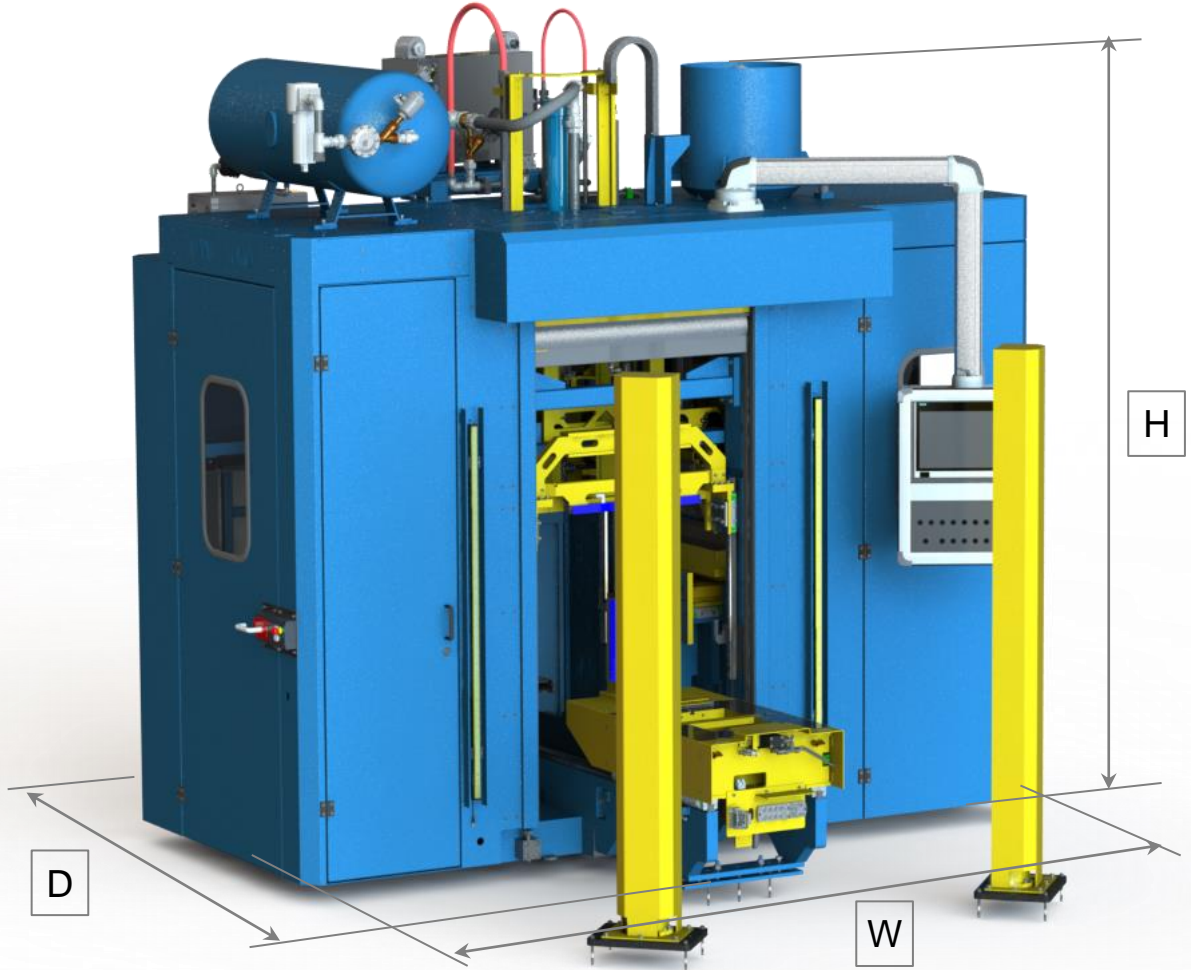

Technical data	CLS-20/25	CLS-20/35
Shoot volume [liters]	max. 25	max. 35
Corebox size maximum [mm]	800 x 800	
Shoot area maximum [mm]	550 x 550	
Corebox weight maximum [kg]	1500	
Closing force horizontal	190 kN	
Dry cycle time* [s]	16	
Machine dimensions WxDxH [mm]	ca. 3800 x 2800 x 3200	

* machine cycle time in automatic mode without parameters for shooting time, gassing, exhaust
 - considering stroke optimized horizontal parted toolings

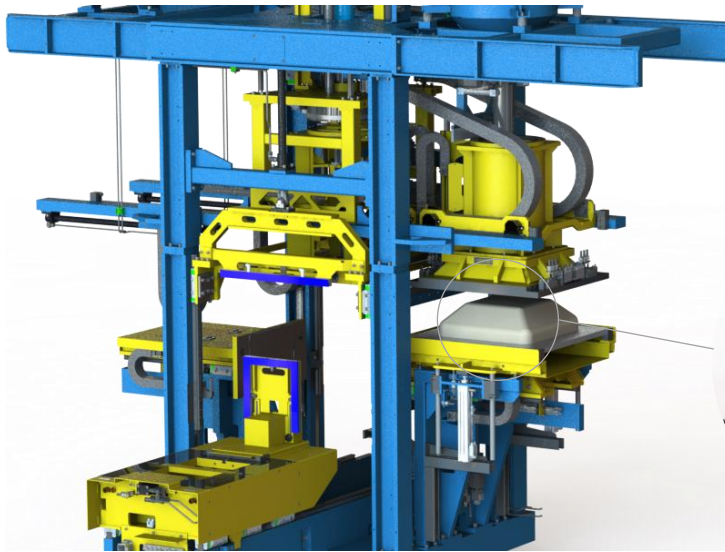

shoot plate cleaning
sand removal

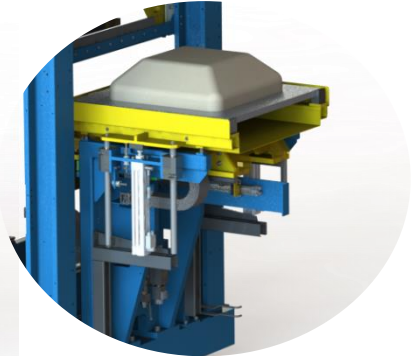

Advantages and special functions

- powerful shooting system
- shootplate cleaning station
- patented high efficient Lüber gassing process
- Energy-efficient hydraulic unit
- state of the art graphical user interface
- all main functions with displacement measuring systems
- no pit/special foundation needed
- for coldbox production process

energy-efficient
hydraulic unit



universal gassing plate
gassing zones can be defined
flexible

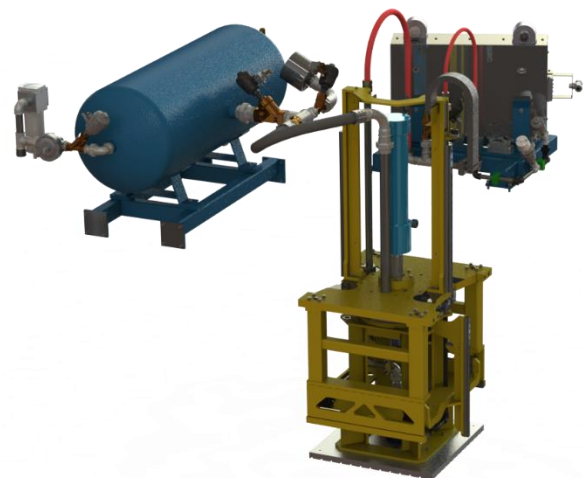

efficient gassing system
due to split supply of
catalyst and purge air
(patented)